

Atomic Orbitals / Electron Configuration

HP Physical Science 9 – Mr. Voight

Is the Modern Theory of the atom the whole story? NO – it is not that the entire theory is incorrect, it's just that our book doesn't give us the whole story.

Let's look at the Modern Theory:

Yes – the electrons are arranged according to energy levels. The energy associated with each level increases as you get farther from the nucleus.

Yes – electrons are located in regions of space called electron clouds, more specifically, we call them **orbitals**.

NO – the orbitals/electron clouds are not all spheres

each orbital can hold up to

The Atomic Orbitals:

s orbitals

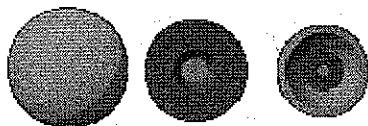

$1 \text{ orbital} \times 2 e^-/\text{orbital} = 2 \text{ "spaces" } 2 e^-$

This picture shows the 1s, 2s, and 3s orbitals

What observations can you make?

p orbitals

p-block is six wide = 3 orbitals / 2 e⁻ each

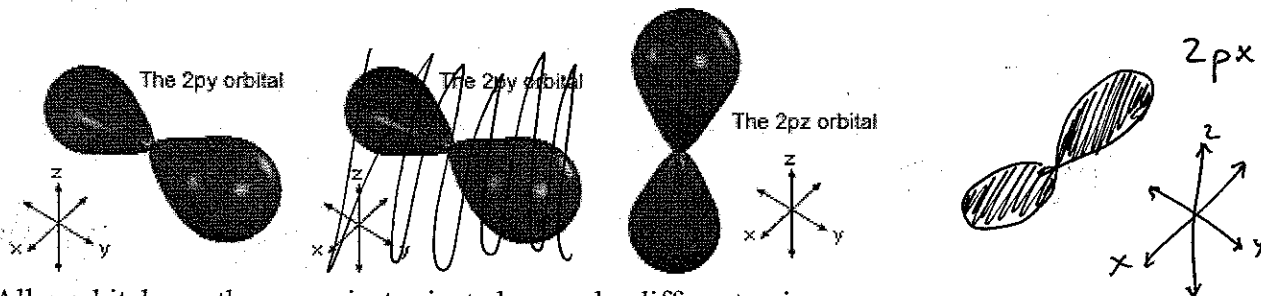

All p orbitals are the same, just oriented around a different axis.

d orbitals

$5 \text{ orbitals} \times 2 e^-/\text{orbital} = 10 \text{ "spaces"}$

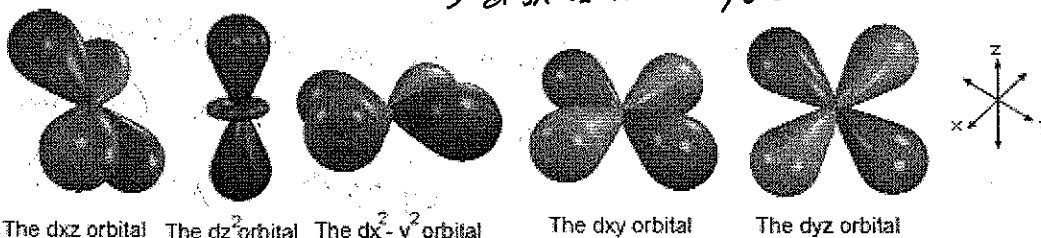

When all of the orbitals are combined, they form a roughly spherical shape:

TABLE 8.3 Electron Configurations of the First Ten Elements

	Electron Configurations		Orbital Box Diagrams				
	Condensed	Expanded	1s	2s	2p _x	2p _y	2p _z
H	1s ¹		↑				
He	1s ²		↑↓				
Li	1s ² 2s ¹		↑↓	↑			
Be	1s ² 2s ²		↑↓	↑↓			
B	1s ² 2s ² 2p ¹		↑↓	↑↓	↑		
C	1s ² 2s ² 2p ²	1s ² 2s ² 2p _x ¹ 2p _y ¹	↑↓	↑↓	↑	↑	
N	1s ² 2s ² 2p ³	1s ² 2s ² 2p _x ¹ 2p _y ¹ 2p _z ¹	↑↓	↑↓	↑	↑	↑
O	1s ² 2s ² 2p ⁴	1s ² 2s ² 2p _x ² 2p _y ¹ 2p _z ¹	↑↓	↑↓	↑↓	↑	↑
F	1s ² 2s ² 2p ⁵	1s ² 2s ² 2p _x ² 2p _y ² 2p _z ¹	↑↓	↑↓	↑↓	↑↓	↑
Ne	1s ² 2s ² 2p ⁶	1s ² 2s ² 2p _x ² 2p _y ² 2p _z ²	↑↓	↑↓	↑↓	↑↓	↑↓

~~Orbital Notation, Noble Gas Notation~~

Should be asked to do THIS for THE TEST!!

Answer the following questions:

- Using your own words, state the Aufbau Principle, Hund's Rule, and Pauli Exclusion Principle.
- Write the electron configuration notation, ~~orbital notation, and noble gas notation~~ of the following elements:
 - Hydrogen
 - Neon
 - Magnesium
 - Sulfur
 - Iron
 - Bromine

As stated previously, orbitals are arranged in an atom based on the energy level of the electrons required to be in that orbital. The energy is as follows:

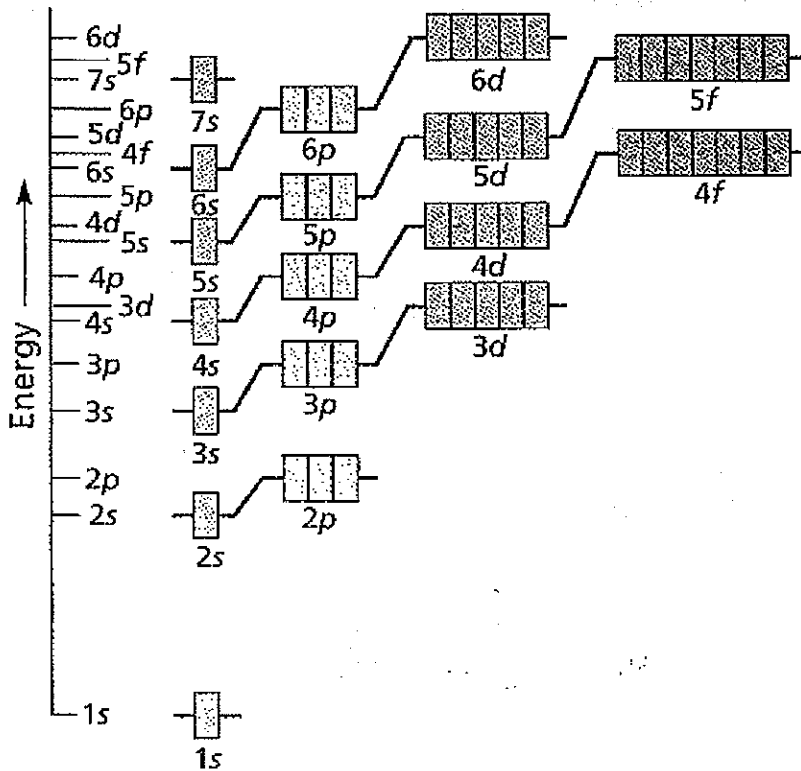

FIGURE 4-16 The order of increasing energy for atomic sublevels is shown on the vertical axis. Each individual box represents an orbital.

"ground state"

The **Aufbau Principle** states that atoms must exist in their lowest energy configuration (most stable form). In order to accomplish this, atomic orbitals at a lower level must be full before placing electrons in a higher level.

Hund's Rule says that each orbital of the same energy must be singly occupied before electrons can be paired. Also, all single electrons residing on the same energy level have the same spin (up or down)

Pauli Exclusion Principle says that no two electrons in an atom can have the same set of quantum numbers (quantum numbers are essentially a description of the electrons location- simply put, if two electrons are located the same orbital, they require opposite spins)

How does this look?